

| REVISIONS | | | |
|-----------|---|-----------|-----------|
| REV. | DESCRIPTION | DATE | APPROVED |
| - | NEW RELEASE | - | - |
| 1 | MOUNTING BRACKET WAS FABRICATED NOW PURCHASED. PLATE WASHERS WERE FABRICATED NOW PURCHASED. | 4/20/2026 | F. BRYANT |

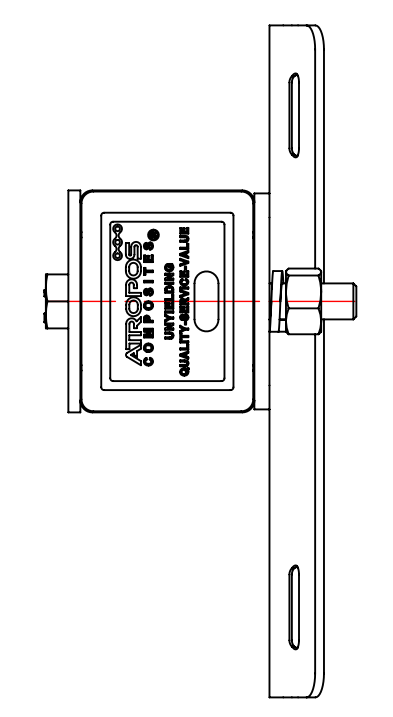
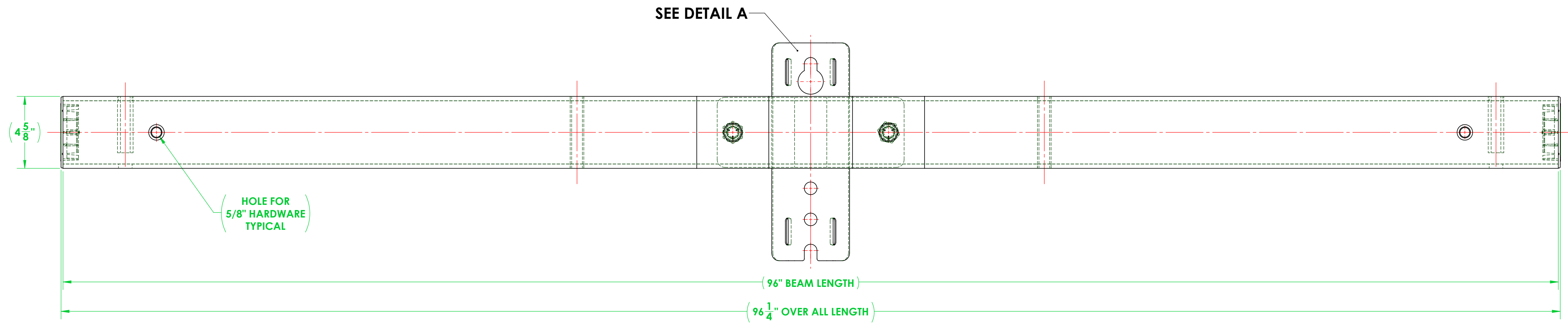
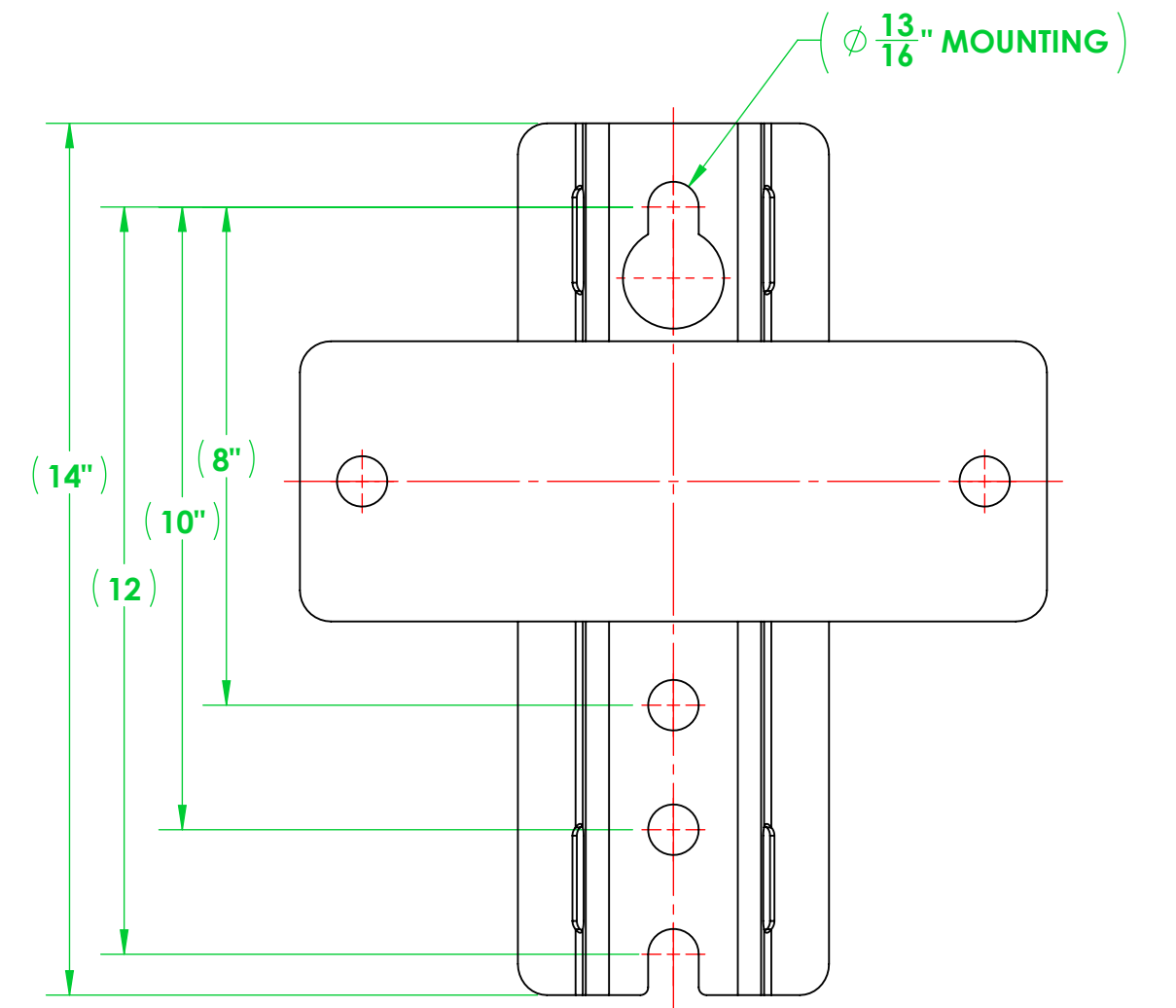
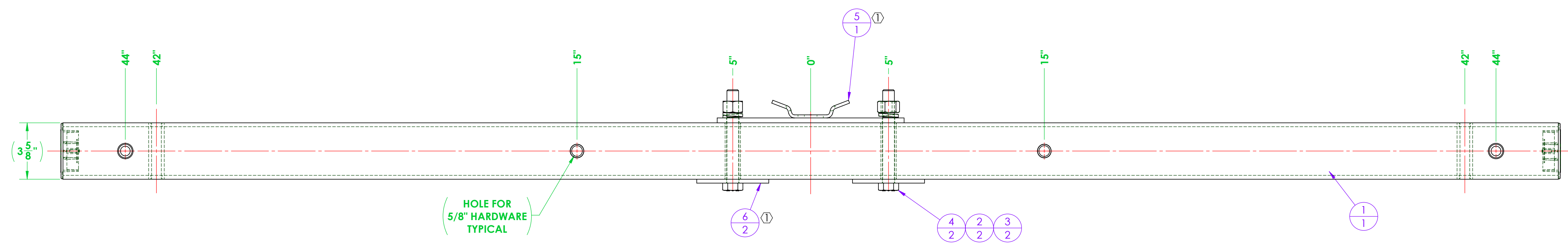

| ITEM NO. | PART NUMBER | DESCRIPTION | QTY. |
|----------|-----------------------|--|------|
| 1 | 3402A096-T011-XR03 CA | ASSEMBLY, 3402, CROSSARM, TANGENT, 8 FT, AMERMEN | 1 |
| 2 | A616-0042-01 | LOCK WASHER, FOR 3/4" SCREW, 0.766" ID, 1.265" OD, 0.188" THICK, HOT-DIPPED GALVANIZED STEEL | 2 |
| 3 | A616-0019-02 | EXTREME STRENGTH NUT, HEX, 3/4"-10, 2H, HOT-DIPPED GALVANIZED | 2 |
| 4 | A616-0020-02 | BOLT, HEX, 3/4"-10 X 6.00" LONG, HOT DIPPED GALVANIZED STEEL, 1-1/8" DRIVE | 2 |
| ① 5 | A700-0042 | CROSSARM MOUNTING BRACKET, TANGENT, 3400 SERIES | 1 |
| ① 6 | A700-0047 | WASHER, SQUARE, 4.625" X 4.625" X 0.25 THICK WITH 0.81 THRU HOLE | 2 |

| | | | | | | | | | |
|---------------|--|--|--------------------------|------|----------|-----|-----|----------------------|---|
| GENERAL NOTES | UNLESS OTHERWISE SPECIFIED | NAME | DATE | | | | | | |
| | DIMENSIONS ARE IN INCHES STANDARD TOLERANCES FRACTIONAL: ±1/32 ANGULAR: MACHINED: ±0.5° BEND: ±2° TWO PLACE DECIMAL: ±0.03 THREE PLACE DECIMAL: ±0.005 INTERPRET GEOMETRIC TOLERANCING PER ANSI Y14.5 | DRAWN: F. BRYANT CHECKED: TJS ENG APPR: MFG APPR: Q.A. | 10/13/2025 10/21/2025 | | | | | | |
| | MATERIAL | PROPRIETARY AND CONFIDENTIAL | | | | | | | |
| | FINISH | THE INFORMATION CONTAINED IN THIS DRAWING IS THE SOLE PROPERTY OF VECTUS. ANY REPRODUCTION IN PART OR AS A WHOLE WITHOUT THE WRITTEN PERMISSION OF VECTUS IS PROHIBITED. | | | | | | | |
| | DO NOT SCALE DRAWING | <table border="1"> <tr> <td>SIZE</td> <td>DWG. NO.</td> <td>REV</td> </tr> <tr> <td>1:8</td> <td>D 3402A096-T011-XR03</td> <td>1</td> </tr> </table> | | SIZE | DWG. NO. | REV | 1:8 | D 3402A096-T011-XR03 | 1 |
| SIZE | DWG. NO. | REV | | | | | | | |
| 1:8 | D 3402A096-T011-XR03 | 1 | | | | | | | |

ATROPOS
COMPOSITES

12208 MISSOURI BOTTOM ROAD, HAZELWOOD, MO 63042
PHONE: 314.714.4001 FAX: 314.895.1943
SALES@LABYRINTH-TECH.COM

TITLE:
ASSEMBLY, RUS, 3402, CROSSARM WITH
GAIN, TANGENT, 8" TYPE 3 DRILL PATTERN

SCALE: 1:8 WEIGHT: 56.08 SHEET 1 OF 1